

The ADS\_E 50/5 is a powerful servo-amplifier for driving permanent magnet DC motors up to 250 watts.

Four modes can be selected by DIP switches on the board:

- Speed control using tacho signals
- Speed control using encoder signals
- IxR compensated speed control
- Torque or current control

The ADS\_E 50/5 is protected against excess current, excess temperature and short circuit on the motor winding.

With the FET power transistors incorporated in the servoamplifier, an efficiency of up to 95% is achieved. A built in motor choke combined with the high PWM frequency of 50 kHz allows the connection of motors with a very low inductivity. In most cases an external choke can be omitted.

Thanks to the wide input power supply range of 12 - 50 VDC, the ADS\_E 50/5 is very versatile and can be used with various power supplies.

The Europa card size allows the unit to be installed in a 19"-subrack or in a plug-in card system. Thanks to the controller circuit design, the ADS\_E 50/5 is easily and quickly installed.

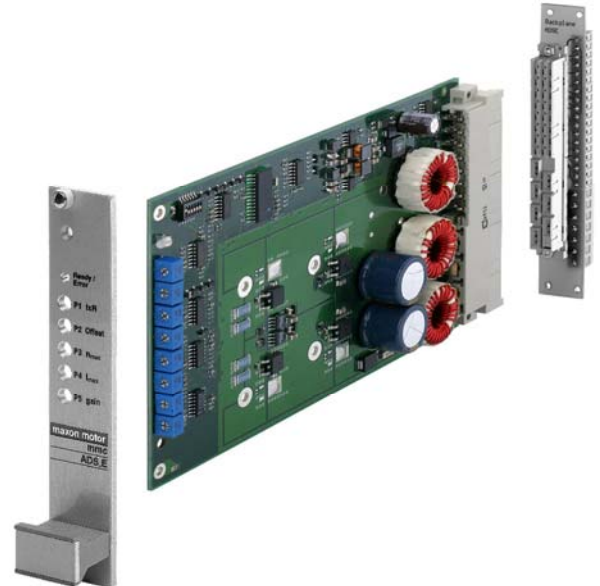

## Table of Contents

1	Safety Instructions .....	2
2	Performance Data .....	3
3	Minimum External Wiring for Different Modes of Operation .....	4
4	Operating Instructions .....	5
5	Functions .....	7
6	Additional Possible Adjustments .....	10
7	Operating Status Display .....	12
8	Error Handling .....	13
9	EMC-compliant installation .....	13
10	Block Circuit Diagram .....	14
11	Pin Allocation Connector DIN 41612 Version H7/F24 .....	14
12	Dimension Drawing .....	15
13	Accessories (not part of delivery) .....	15

The latest edition of these operating instructions may be downloaded from the internet as a PDF-file under [www.maxonmotor.com](http://www.maxonmotor.com), category «Service & Downloads», Order number 166143.

## 1 Safety Instructions



### Skilled Personnel

Installation and starting of the equipment shall only be performed by experienced, skilled personnel.



### Statutory Regulations

The user must ensure that the servoamplifier and the components belonging to it are assembled and connected according to local statutory regulations.



### Load Disconnected

For primary operation the motor should be free running, i.e. with the load disconnected.



### Additional Safety Equipment

An electronic apparatus is not fail-safe in principle. Machines and apparatus must therefore be fitted with independent monitoring and safety equipment. If the equipment breaks down, if it is operated incorrectly, if the control unit breaks down or if the cables break, etc., it must be ensured that the drive or the complete apparatus is kept in a safe operating mode.



### Repairs

Repairs may be made by authorised personnel only or by the manufacturer. It is dangerous for the user to open the unit or make repairs to it.



### Danger

Do ensure that during the installation of the ADS\_E 50/5 no apparatus is connected to the electrical supply. After switching on, do not touch any live parts.



### Max. Supply Voltage

Make sure that the supply voltage is between 12 and 50 VDC. Voltages higher than 53 VDC or of wrong polarity will destroy the unit.



### Short circuit and earth fault

The ADS\_E 50/5 amplifier is not protected against winding short circuits against ground safety earth or Gnd!



### Motor choke

The built in motor choke allows operation with almost all maxon DC motors with an output power higher than 10 Watt. If necessary the motor continuous current must be slightly reduced.

### Generally the following applies:

$$L_{\text{extern}} [\text{mH}] \geq \frac{V_{\text{CC}} [\text{V}]}{0.15 \left[ \frac{1}{\text{s}} \right] \cdot I_{\text{D}} [\text{mA}]} - 0.15 [\text{mH}] - \frac{L_{\text{Motor}} [\text{mH}]}{3}$$

- Supply voltage  $V_{\text{CC}}$  [V]
- Nominal current (Max. continuous output current)  $I_{\text{D}}$  [mA]
- Terminal inductance  $L_{\text{Motor}}$  [mH]

### Sought value:

- Additional required external inductance so that the continuous current only reduces by max. 10% as a result of warming.



### Electrostatic Sensitive Device (ESD)

## 2 Performance Data

### 2.1 Electrical data

Supply voltage $V_{CC}$ (Ripple < 5%).....	12 - 50 VDC
Max. output voltage .....	$0.9 \cdot V_{CC}$
Max. output current $I_{max}$ .....	10 A
Continuous output current $I_{cont}$ .....	5 A
Switching frequency.....	50 kHz
Max. Efficiency .....	95 %
Band width current controller .....	2.5 kHz
Built-in motor choke .....	150 $\mu$ H / 5 A

### 2.2 Inputs

"Set value" .....	-10 ... +10 V ( $R_i = 20 \text{ k}\Omega$ )
"Enable" .....	+4 ... +50 VDC ( $R_i = 15 \text{ k}\Omega$ )
Input voltage DC tacho "Tacho Input" .....	min. 2 VDC, max. 50 VDC ( $R_i = 14 \text{ k}\Omega$ )
Encoder signals "Channel A, A\, B, B\ " .....	max. 100 kHz, TTL level

### 2.3 Outputs

Current monitor "Monitor I", short-circuit protected .....	-10 ... +10 VDC ( $R_o = 100 \Omega$ )
Speed monitor "Monitor n", short-circuit protected .....	-10 ... +10 VDC ( $R_o = 100 \Omega$ )
Status reading "READY"	
Open collector .....	max. 30 VDC ( $I_L \leq 20 \text{ mA}$ )

### 2.4 Voltage outputs

Aux. voltage, short-circuit protected .....	+12 VDC, -12 VDC, max. 12 mA ( $R_o = 1 \text{ k}\Omega$ )
Encoder supply voltage .....	+5 VDC, max. 80 mA

### 2.5 Trim potentiometers

IxR compensation  
 Offset  
 $\eta_{max}$   
 $I_{max}$   
 gain

### 2.6 LED indicator

Bi-colour LED .....	READY / ERROR green = READY, red = ERROR
---------------------	---------------------------------------------

### 2.7 Ambient temperature- / Humidity range

Operating.....	-10 ... +45°C
Storage .....	-40 ... +85°C
noncondensating .....	20 ... 80 %

### 2.8 Mechanical data

Weight .....	approx. 175 g
Dimensions .....	see dimension drawing, <a href="#">chapter 12</a>

### 2.9 Terminal

Connector DIN 41612.....	Version H7/F24
--------------------------	----------------

### 3 Minimum External Wiring for Different Modes of Operation

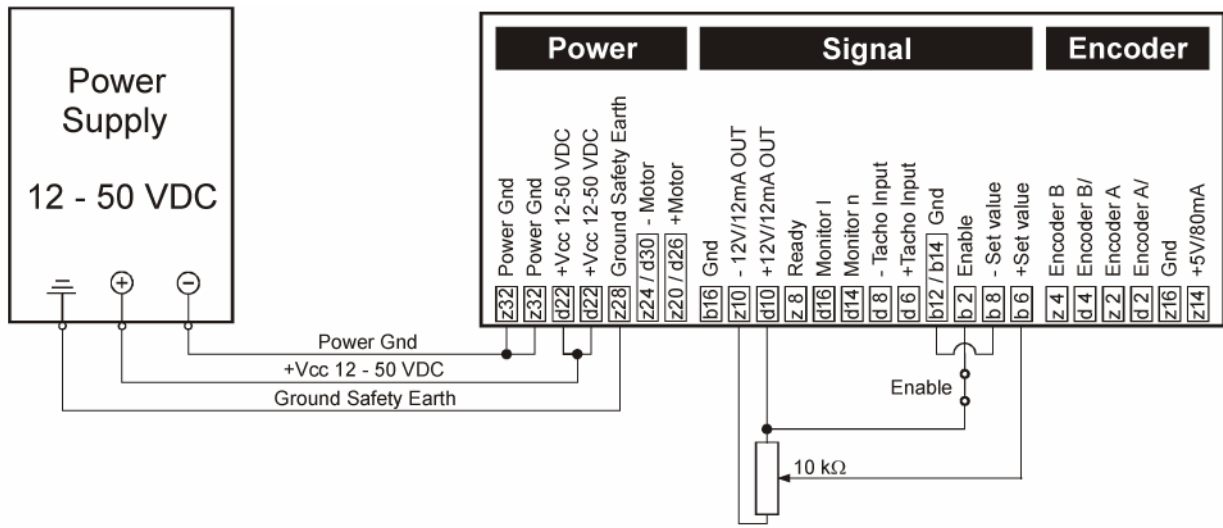

#### IxR

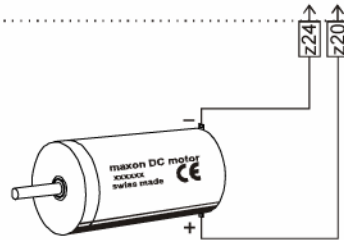

#### Tacho

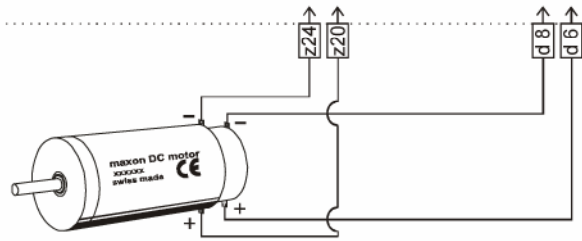

#### Encoder

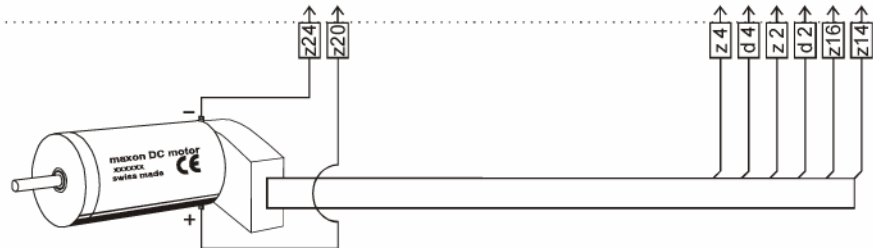

#### Current

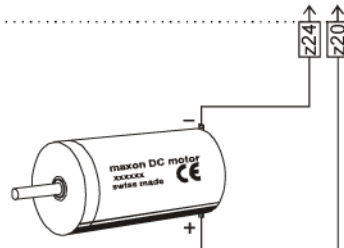

## 4 Operating Instructions

### 4.1 Determine power supply requirements

You may make use of any available power supply, as long as it meets the minimal requirements spelled out below.

During set up and adjustment phases, we recommend separating the motor mechanically from the machine to prevent damage due to uncontrolled motion.

#### Power supply requirements

Output voltage	$V_{CC}$ min. 12 VDC; max. 50 VDC
Ripple	< 5 %
Output current	depending on load, continuous 5 A (short-time 10 A)

The required voltage can be calculated as follows:

#### Known values

- ⇒ Operating torque  $M_B$  [mNm]
- ⇒ Operating speed  $n_B$  [rpm]
- ⇒ Nominal motor voltage  $U_N$  [V]
- ⇒ Motor no-load speed at  $U_N$ ,  $n_0$  [rpm]
- ⇒ Speed/torque gradient of the motor  $\Delta n/\Delta M$  [rpm/mNm]

#### Sought values

- ⇒ Supply voltage  $V_{CC}$  [V]









#### Solution

$$V_{CC} = \frac{U_N}{n_0} \cdot \left( n_B + \frac{\Delta n}{\Delta M} \cdot M_B \right) \cdot \frac{1}{0.9} + 2 \text{ [V]}$$

Choose a power supply capable of supplying this calculated voltage under load. The formula takes into account a max. PWM cycle of 90 % and a 2 V max. voltage drop.

**Note:** The power supply must be able to buffer the back-fed energy from brake operation e.g. in a condenser. With electronically stabilized power supply units it is to ensure, that the overcurrent protection responds in no operating condition.









### 4.2 Function of the potentiometers

LED	Potentiometer	Function	Turn to the		
			left ↶	right ↷	
 P1	P1	IxR	IxR compensation	weak compensation	strong compensation
 P2	P2	Offset	Adjustment $n=0$ / $I=0$ at set value 0 V	motor turns CCW	motor turns CW
 P3	P3	$n_{max}$	max. speed at 10 V set value	speed slower	speed faster
 P4	P4	$I_{max}$	current limit	lower min. 0.5 A	higher max. 10 A
 P5	P5	gain	amplification	lower	higher
 P6	P6	<ul style="list-style-type: none"> <li>• For additional possible adjustments refer to <a href="#">chapter 6</a>.</li> <li>• In use with the original frontplate, the potentiometers are covered!</li> </ul>			
 P7	P7				
 P8	P8				

## 4.3 Adjustment of the Potentiometers

### 4.3.1 Pre-adjustment

With the pre-adjustment, the potentiometers are set in a preferred position. ADS\_E units in original packing are already pre-adjusted.

Pre-adjustment			
 P1	<b>P1</b>	<b>I<sub>xR</sub></b>	<b>0 %</b>
 P2	<b>P2</b>	<b>Offset</b>	<b>50 %</b>
 P3	<b>P3</b>	<b>n<sub>max</sub></b>	<b>50 %</b>
 P4	<b>P4</b>	<b>I<sub>max</sub></b>	<b>50 %</b>
 P5	<b>P5</b>	<b>gain</b>	<b>10 %</b>
 P6	P6	n <sub>gain</sub>	25 %
 P7	P7	I <sub>gain</sub>	40 %
 P8	P8	I <sub>cont</sub>	50 %

Adjustment:  
refer to [section 4.3.2](#)

Additional possible adjustments:  
refer to [section 6.1/6.2](#)

### 4.3.2 Adjustment

#### Encoder mode DC-Tacho mode I<sub>xR</sub> compensation

- Adjust set value to maximum (e.g. 10 V) and turn potentiometer **P3** n<sub>max</sub> so far that the required speed is achieved.
- Set potentiometer **P4** I<sub>max</sub> to the limiting value desired. Maximum current in the 0 ... 10 A range can be adjusted in linear fashion with potentiometer **P4**.  
**Important:** The limiting value I<sub>max</sub> should be below the nominal current (max. continuous current) as shown on the motor data sheet and may not exceed 5 A continuously.
- Increase potentiometer **P5** gain slowly until the amplification is set large enough.  
**Caution:** If the motor vibrates or becomes loud, the amplification is adjusted too high.
- Adjust set value to 0 V. Then set the motor speed to 0 rpm with the potentiometer **P2** Offset.

#### In addition, only in the case of I<sub>xR</sub> compensation:

- Slowly increase potentiometer **P1** I<sub>xR</sub> until the compensation is set large enough so that in the case of high motor load the motor speed remains the same or decreases only slightly.  
**Caution:** If the motor vibrates or becomes loud, the amplification is adjusted too high.

#### Current controller mode

- Set potentiometer **P4** I<sub>max</sub> to the limiting value desired. Maximum current in the 0 ... 10 A range can be adjusted in linear fashion with potentiometer **P4**.  
**Important:** The limiting value I<sub>max</sub> should be below the nominal current (max. continuous current) as shown on the motor data sheet and may not exceed 5 A continuously.
- Adjust set value to 0 V. Then set the motor current to 0 A with the potentiometer **P2** Offset.

#### Note

- A set value in the -10 ... +10 V range is equal to a current range of approx. +I<sub>max</sub> ... -I<sub>max</sub>.
- Configured as a current controller, **P1**, **P3** and **P5** are not activated.

## 5 Functions

### 5.1 Inputs

#### 5.1.1 "Set value"

The set value input is wired as a differential amplifier.

Input voltage range	-10 ... +10 V
Input circuit	differential
Input resistance	20 k $\Omega$ (differential)
Positive set value	( + Set Value) > ( - Set Value) negative motor voltage or current motor shaft turns CCW
Negative set value	( + Set value) < ( - Set Value) positive motor voltage or current motor shaft turns CW

#### 5.1.2 "Enable"

If a voltage is given at "Enable", the servoamplifier switches the motor voltage to the winding connections. If the "Enable" input is not switched on or is connected to the Gnd, the power stage will be highly resistant and will be disabled. The "Enable" input is short-circuit protected.

Enable	Minimum input voltage	+4.0 VDC
	Maximum input voltage	+50 VDC
	Input resistance	15 k $\Omega$
	Switching time	typ. 500 $\mu$ s (@ 5 V)
Disable	Minimum input voltage	0 VDC
	Maximum input voltage	+2.5 VDC
	Input resistance	15 k $\Omega$
	Switching time	typ. 100 $\mu$ s (@ 0 V)

#### 5.1.3 "DC Tacho"

Minimum input voltage	2.0 V
Maximum input voltage	50 V
Input resistance	14 k $\Omega$

##### Speed control range

The speed range is set using Potentiometer **P3**  $n_{\max}$  (max. speed at maximum set value).

For full speed control with  $\pm 10$  V, the tacho input voltage range must be at least  $\pm 2$  V.

##### Example for DC-Tacho with 0.52 V / 1000 rpm

2.0 V tacho voltage is equivalent to a speed of approx. 3850 rpm. If the full set value range has been used, the lowest adjustable speed with the  $n_{\max}$  potentiometer is 3850 rpm.

Lower speed ranges can be reached through a reduced set value range or by using a DC tacho with a higher output voltage, such as 5 V / 1000 rpm.

#### 5.1.4 “Encoder”

Encoder supply voltage	+5 VDC max. 80 mA	
Maximum encoder frequency	DIP switch <b>S5</b> ON:	10 kHz
	DIP switch <b>S5</b> OFF:	100 kHz
Voltage value	TTL	
	low	max. 0.8 V
	high	min. 2.0 V

It is strongly recommended that the encoder be used with a built-in line driver. If the encoder is used **without** a line driver (without Encoder A\ and Encoder B\), speed breakdowns and max. speed limits must be expected because of the slower switching slope.

The servoamplifier does not need any home impulse I and II.



## 5.2 Outputs

### 5.2.1 Current monitor “Monitor I”

The servoamplifier makes a current actual value available for monitoring purposes. The signal is proportional to the motor current. The “Monitor I” output is short-circuit protected.

Output voltage range	-10 ... +10 VDC
Output resistance	100 $\Omega$
Gradient	approx. 0.8 V/A
positive voltage on current monitor output	corresponds to a negative motor current
negative voltage on current monitor output	corresponds to a positive motor current

### 5.2.2 Speed monitor “Monitor n”

The speed monitor is primarily intended for the qualitative estimation of the dynamics. The absolute speed is determined by the properties of the speed sensors and by the setting of the  $n_{\max}$  potentiometer. The output voltage of the speed monitor is proportional to the number of revolutions. The output voltage of the speed monitor is 10 V when the maximum number of revolutions set by the  $n_{\max}$  potentiometer has been reached. The “Monitor n” output is short-circuit protected.

Output voltage range	-10... +10 VDC		
Output resistance	100 $\Omega$		
Example:	-10 V	corresponding speed	$-n_{\max}$ (CCW)
	0 V	corresponding speed	0 rpm
	+10 V	corresponding speed	$+n_{\max}$ (CW)

### 5.2.3 Status reading “Ready”

The “Ready” signal can be used to report the state of operational readiness or a fault condition on a master control unit. The “Open Collector” output is, in normal cases, i.e. no faults, switched to Gnd. In the case of a fault due to excess temperature, excess current, voltage processing error or too high encoder input frequency, the output transistor is not conducting (high resistance).

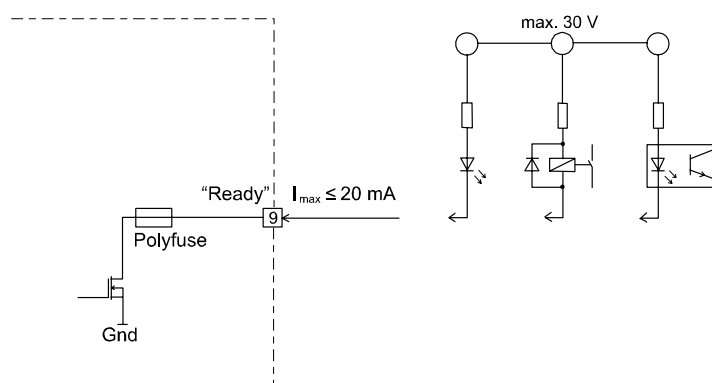

An external additional voltage is required:

Input voltage range	max. 30 VDC
Load current	$\leq 20$ mA

**Note:**

The fault condition is stored. In order to reset the fault condition, the servoamplifier must be re-released (Enable). If the cause of the fault situation cannot be removed, the output transistor will immediately change to the not conducting state again.

## 6 Additional Possible Adjustments

Potentiometer	Function	Position		
		left ↶	right ↷	
P6	$n_{\text{gain}}$	speed gain	low	high
P7	$I_{\text{gain}}$	current gain	low	high
P8	$I_{\text{cont}}$	continuous current limit	lower	higher

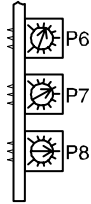

### 6.1 Adjustments potentiometer P6 $n_{\text{gain}}$ and potentiometer P7 $I_{\text{gain}}$

In most applications, regulation setting is completely satisfactory using potentiometers **P1** to **P5**. In special cases the transient response can be optimized by setting the **P6**  $n_{\text{gain}}$  potentiometer. The **P7**  $I_{\text{gain}}$  potentiometer can, in addition, be adapted to the dynamics of the current regulator.

It is recommended that the success of changes to the settings of **P6** and **P7** be checked by measuring the transient response with an oscilloscope at the “Monitor n” and “Monitor I” outputs.

Pre-adjustment: **P6**  $n_{\text{gain}} = 25\%$  and **P7**  $I_{\text{gain}} = 40\%$ .

### 6.2 Adjustments potentiometer P8 $I_{\text{cont}}$ and current limit mode DIP switch S6

It is standard that a maximum current limiter is activated (DIP switch **S6** OFF) as the only current limiter. In this way the motor current is limited to the value set on potentiometer **P4**  $I_{\text{max}}$  (0.5 ... 10 A).

If DIP switch **S6** is turned to ON, a cyclical current limiter is also activated. This current limiter method makes a certain level of motor protection against thermal overload possible.

For 0.1 seconds the motor current is limited to the value set on potentiometer **P4**  $I_{\text{max}}$  (0.5 ... 10 A) and then for 0.9 seconds current is limited to the value set on potentiometer **P8**  $I_{\text{cont}}$  (0.5 ... 10 A). After 1 second the cycle will repeat itself.

Pre-adjustment: DIP switch **S6** = OFF and **P8**  $I_{\text{cont}} = 50\%$ .

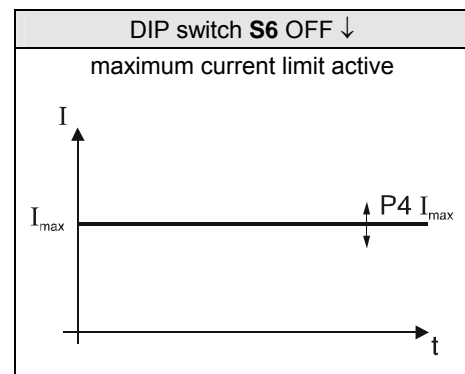
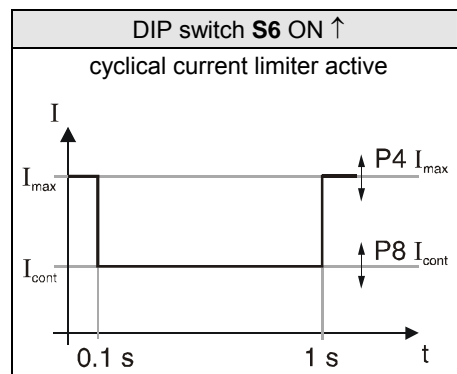

### 6.3 Maximal encoder frequency DIP switch S5

DIP switch **S5** permits selection of the maximum encoder input frequency.  
A max. encoder frequency of 100 kHz is standard.

DIP switch <b>S5</b> ON ↑		DIP switch <b>S5</b> OFF ↓	
Max. Input frequency is 10 kHz		Max. Input frequency is 100 kHz	
Encoder pulse per turn	maximum motor speed	Encoder pulse per turn	maximum motor speed
16	37 500 rpm		
32	18 750 rpm		
64	9 375 rpm		
128	4688 rpm	128	46 875 rpm
256	2344 rpm	256	23 438 rpm
500	1200 rpm	500	12 000 rpm
512	1172 rpm	512	11 719 rpm
1000	600 rpm	1000	6000 rpm
1024	586 rpm	1024	5859 rpm

**Note:**

To achieve good control characteristics, encoders with low impulse counts per turn should be run with the DIP switch **S5** ON ↑.

## 7 Operating Status Display

A bi-colour red/green LED shows the operating mode.

### 7.1 No LED

Reason:

- No supply voltage
- Fuse fault
- Wrong polarity of supply voltage
- Short circuit of the +5 V output

### 7.2 Green LED (normal operation)

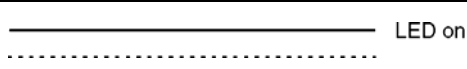
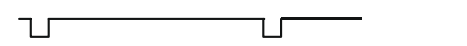
Blink pattern (green LED)	Operating status
	Amplifier is activated (Enable)
	Disable function active

### 7.3 Red LED

According to the blink pattern the following error messages can be identified:

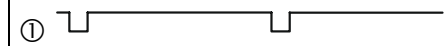
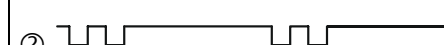
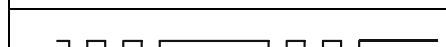
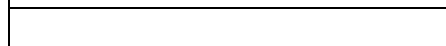
Blink pattern (red LED)	Operating Conditions
① 	If the power stage temperature exceeds a limit of approx. 90°C, the power stage is switched off (disable status).
② 	If a motor current of more than approx. +/- 12.5 A is detected at the current actual value, the power stage will be switched off (disable status).
③ 	If the internal supply voltage cannot be set-up as expected the power amplifier is switched off (disable status).
④ 	If the input frequency at the encoder input is > 150 kHz, the power amplifier is switched off.

The fault condition is stored. In order to reset the fault condition, the servoamplifier must be re-released (Enable). If the cause of the fault condition cannot be eliminated, the error output will be disabled again immediately.

Reason:

- High ambient temperature (blink pattern ①)
- max. continuous current > 5 A (blink pattern ①)
- bad convection (blink pattern ①)
- Short circuit on the motor winding (blink pattern ②)

## 8 Error Handling

Defect	Possible source of defect	Measures
Shaft does not rotate	Supply voltage < 12 VDC	check power plug pin [d22]
	Enable not activated	check signal plug pin [b2]
	Set value is 0 V	check signal plug pin [b6] and pin [b8]
	Current limit too low	check adjustment potentiometer <b>P4 I<sub>max</sub></b>
	Wrong operational mode	check DIP switch settings
	Bad contacts	check wiring
	Wrong wiring	check wiring
Speed is not controlled	Encoder mode: encoder signals	check encoder signal
	DC- Tacho mode: tacho signals	check pin [d6] and [d8] (polarity)
	IxR mode: compensation wrong	check adjustment potentiometer <b>P1 IxR</b>

## 9 EMC-compliant installation

### Power supply (+V<sub>CC</sub> - Power Gnd)

- No shielding normally required.
- Star point-shaped wiring if several amplifiers are supplied by the same power supply.

### Motor cable

- Shielded cable highly recommended.
- Connect shielding on both sides:  
 ADS\_E 50/5 side: Pin 28 "Ground Safety Earth" and/or parts with low resistive connection to the front plane.  
 Motor side: Motor housing or with motor housing mechanical design with low resistive connection.
- Use separate cable.

### Encoder cable

- Although the ADS\_E 50/5 can also be operated without a line driver, using an encoder with a line driver is recommended as this improves interference resistance.
- No shielding normally required.
- Use separate cable.

### Analogue signals (Set value, Tacho, Monitor)

- No shielding normally required
- Use cable shielding with analogue signals with small signal level and electromagnetically harsh environment
- Normally connect shielding on both sides. Place shielding on one side if there are 50/60 Hz interference problems.

### Digital signals (Enable, Ready)

- No shielding necessary

See also block diagram in chapter 10.

**In practical terms, only the complete equipment, comprising all individual components (motor, amplifier, power supply unit, EMC filter, cabling etc.) can undergo an EMC test to ensure interference-free CE-approved operation.**

### 10 Block Circuit Diagram

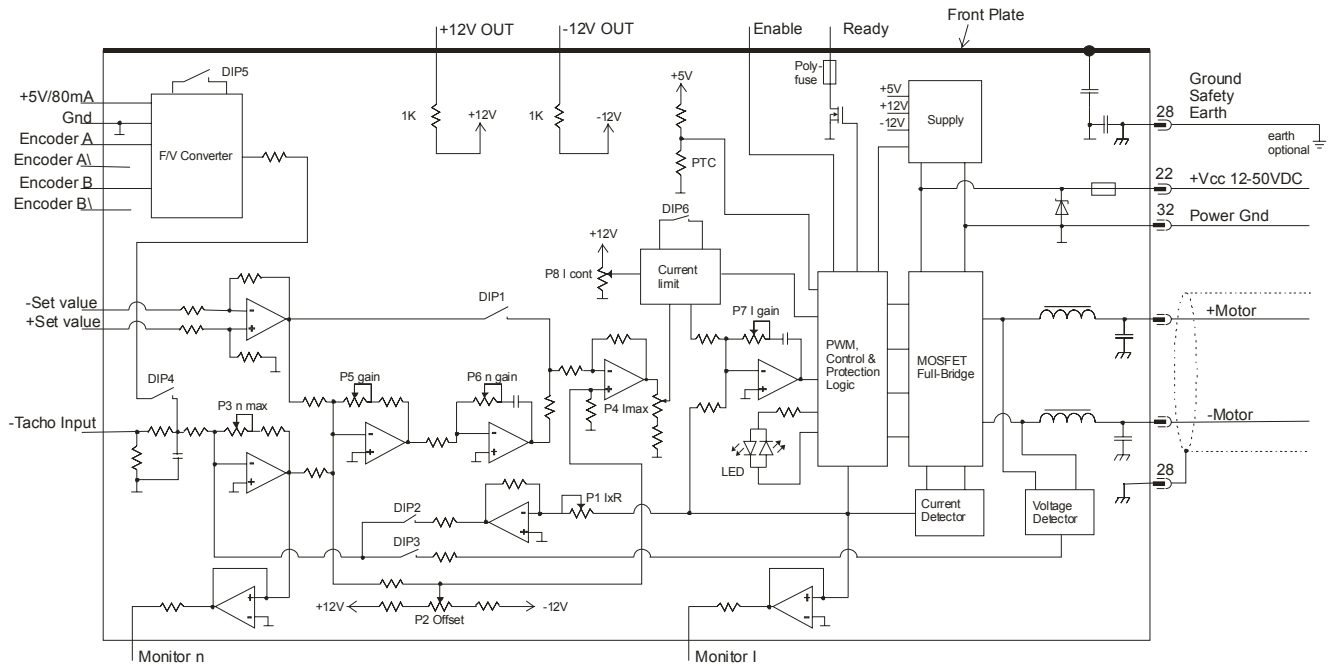

### 11 Pin Allocation Connector DIN 41612 Version H7/F24

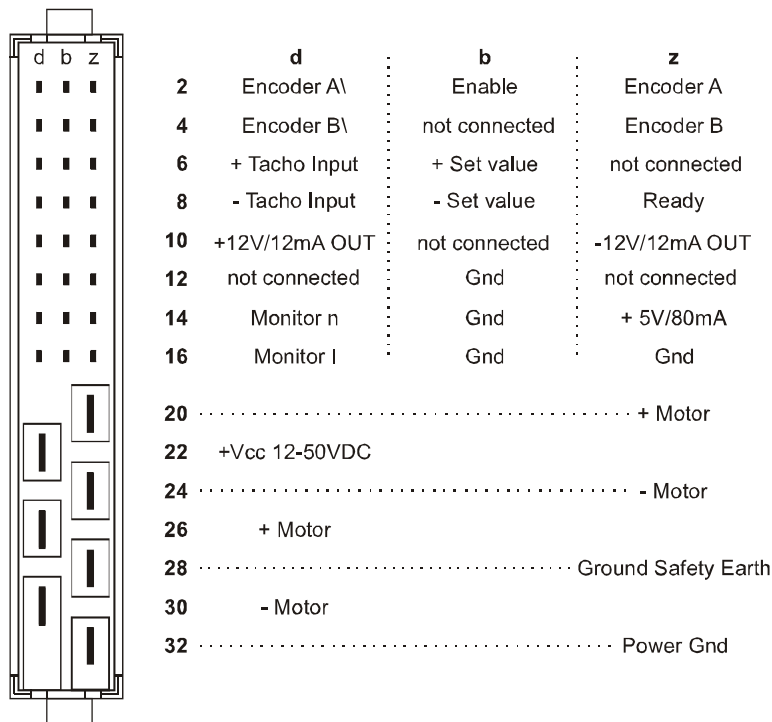

## 12 Dimension Drawing

Dimensions in [mm]

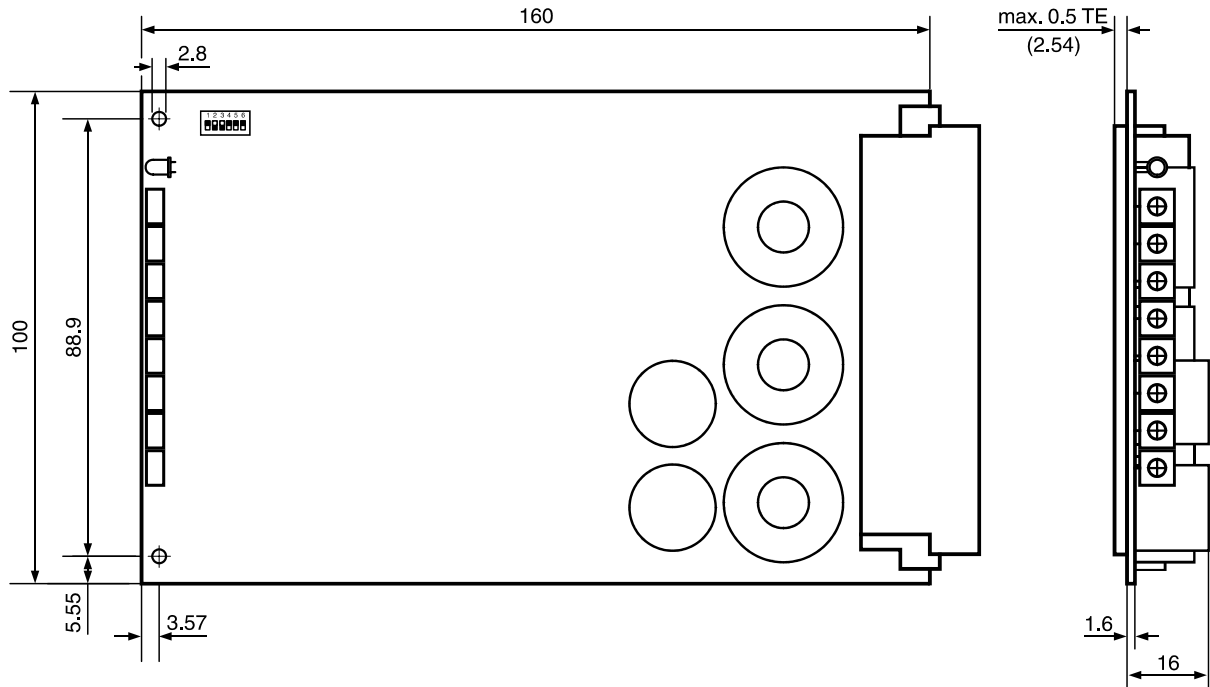

## 13 Accessories (not part of delivery)

### 13.1 Front panel: Order number 167850

Dimensions in [mm]

natural-colored  
anodised  
on both sides  
5 TE, 3 HE

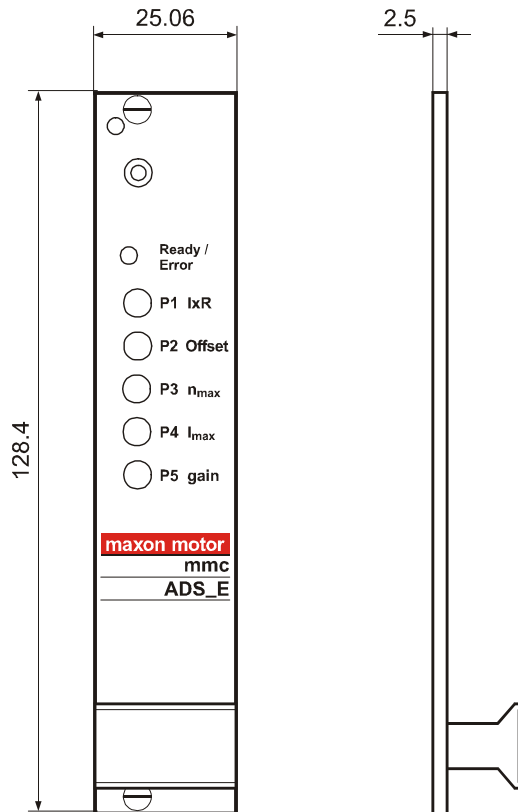

### 13.2 Backplane with screw terminals: Order number 166873

Dimensions in [mm]

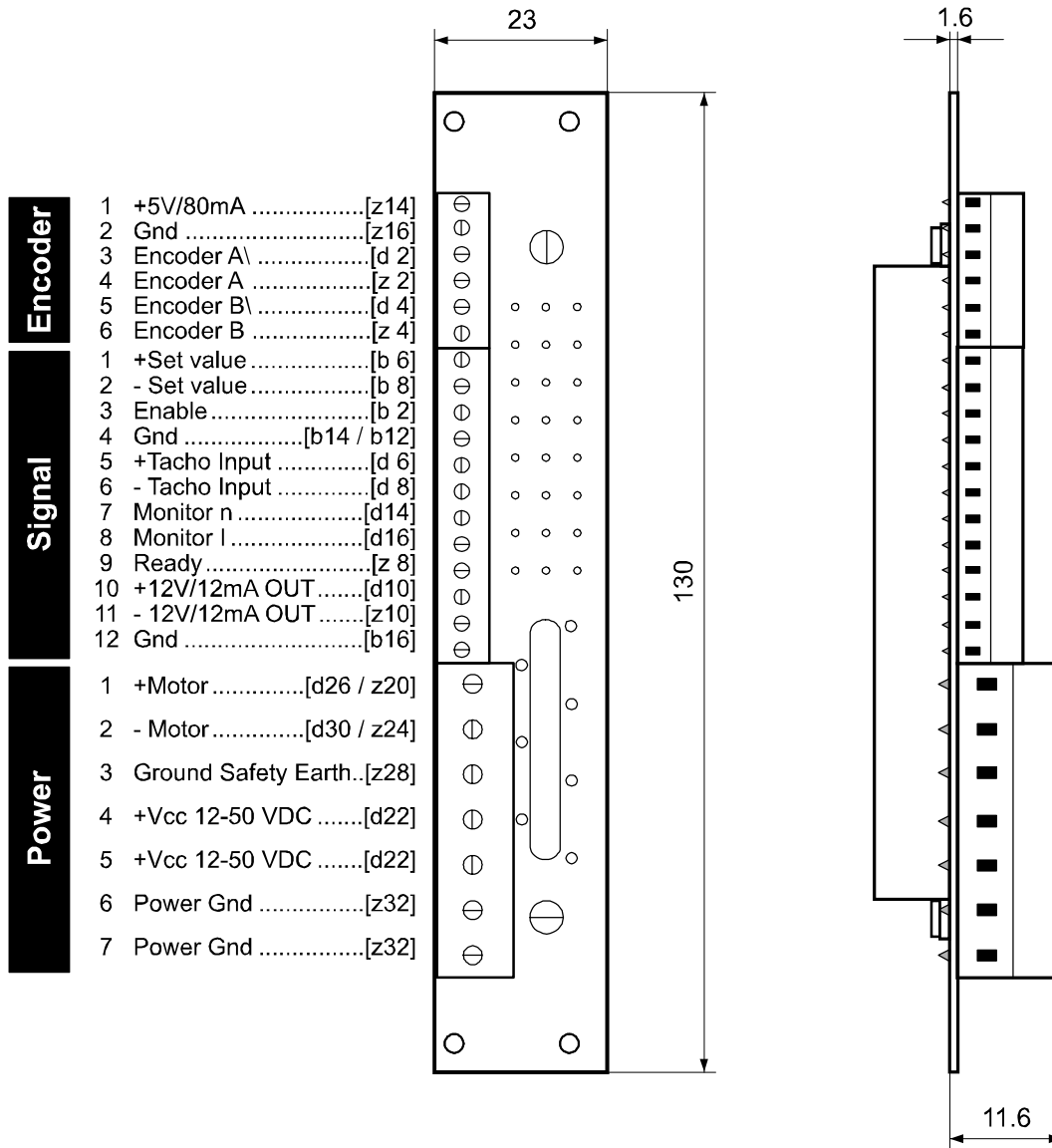

	No. of poles	Pitch	suitable for wire cross section
<b>Encoder</b>	6	3.81 mm	0.14 - 1.5 mm <sup>2</sup> (single wire) 0.10 - 1.0 mm <sup>2</sup> (multiple-stranded wire)
<b>Signal</b>	12	3.81 mm	0.14 - 1.5 mm <sup>2</sup> (single wire) 0.10 - 1.0 mm <sup>2</sup> (multiple-stranded wire)
<b>Power</b>	7	5.08 mm	0.14 - 1.5 mm <sup>2</sup> (single wire) 0.14 - 1.5 mm <sup>2</sup> (multiple-stranded wire)